

Please
follow the
instructions in
this owners guide
carefully. Save this owners
guide for future reference.

Owner's Guide



Solar Water Heater



From

A U R O R E
Auroville Renewable Energy



Dear Friends,

Greetings from Aurore. Congratulations on acquiring an 'Aura' solar water heater. You have joined a growing family of conscious change-makers who have started using renewable energy for their daily use. You are saving precious electricity and contributing towards the reduction of harmful carbon dioxide emitted in the production of electricity. Through our network partners we will ensure that you are able to derive the maximum benefit from your solar water heater.

Here is some background on our organization. Aurore is located within Auroville International Township near Puducherry. Our goal is to provide high quality products and services in the area of renewable energy and energy-efficiency. Our aim is to work towards building a society which derives its energy from renewable sources of energy. Sun, a gift of Mother Nature, makes inexhaustible energy available to us. Any efforts towards harnessing energy from the Sun is a contribution towards conserving life on earth.

Our engineers and researchers are on the constant look-out for reliable and affordable solar energy solutions for domestic and commercial usage. Our aim is to provide high quality products at affordable prices. To ensure long-lasting performance, we tie up with our network partners to provide dependable service and after-care for your valuable asset.

We hope that you find using your solar water heater a satisfying experience. We would be happy to receive your valuable feedback in our efforts towards improving our products and services.

Wishing you a happy and sunny future.

-Aurore Team-



Contents

Chapter	Page
1. Solar Water Heater Parts	4
2. Safety Guide	5
3. Working Principle	8
4. Performance	9
5. Installation Tips	10
6. Optimal Usage	13
7. After Care Do's/Don'ts	15
8. Trouble Shooting	18
9. Technical Specifications	21
10. Accessories	22
11. Warranty	23

Glass Tube Water Heater (Evacuated Tube Collector "ETC")

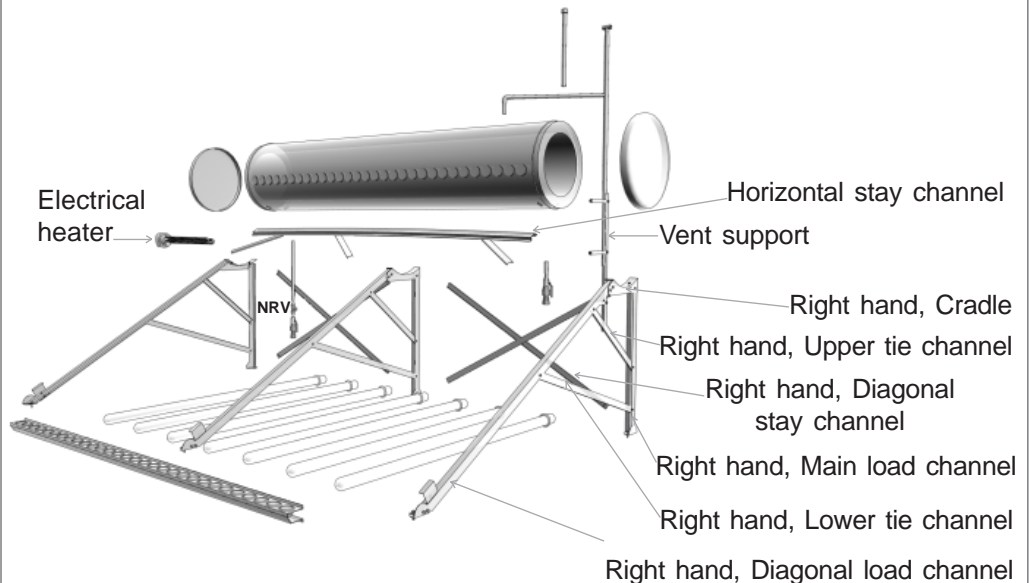
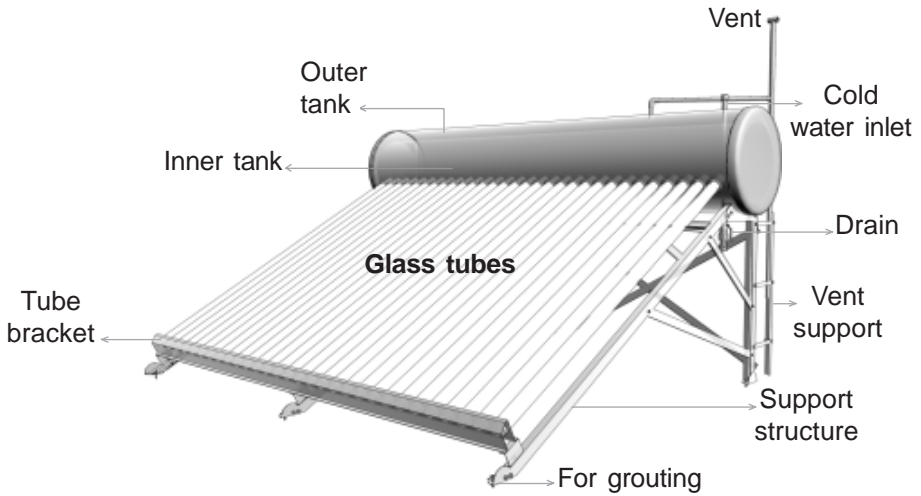

Safety Guide



NOTE : Before installing the Solar Water Heater

Place the evacuated glass tube collector out of reach of children and infants.

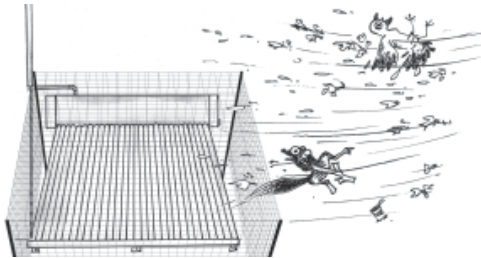
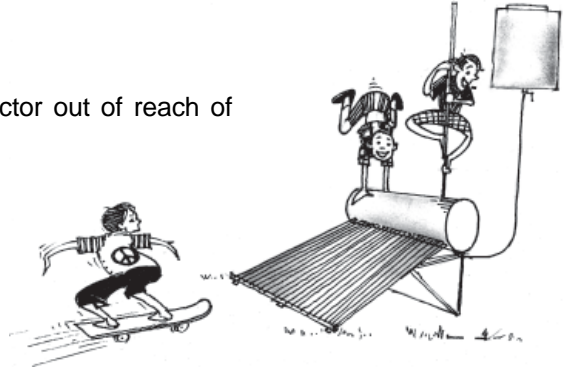

If there is a risk of hailstorms in your locality, additional protection should be provided to the Evacuated Glass tubes by means of a **mesh**.

If monkeys or other animals are a menace in your locality, additional protection should be provided to the glass tubes with a **mesh** and vent pipe which is properly supported.

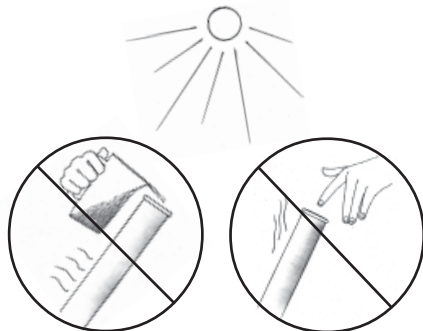

Do not touch or put cold water inside the glass tube if the tube has been exposed to sun without water.

The back-up electrical element should be installed by a trained electrician who should provide a proper earth connection and protect the cable connections from water and moisture.

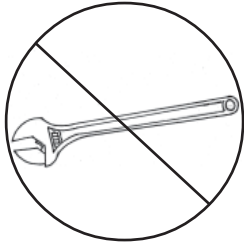

Do not use a pipe wrench for installation of pipe lines.



NOTE : Before using the Solar Water Heater

Test water before bathing, Hot water above 50 °C can cause severe burns



Households with small children, disabled, or elderly persons should use hot water only under adult supervision

Use back-up electrical element only when required. It is recommended to switch OFF the electrical element before taking a bath.



CAUTION !

Do not drop hard objects on the glass tubes.

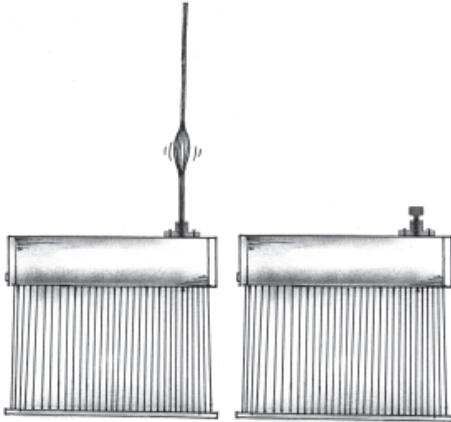
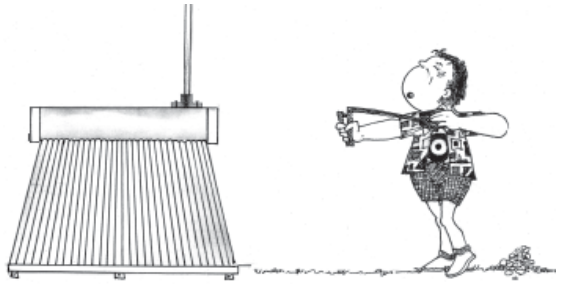

Blockage or damage to the vent pipe can create severe damage to the solar water heater. Should this occur, call the authorized service provider immediately. In case of emergency, like breakage of tubes or leakage in tank, close the cold

water inlet and hot water outlet valves immediately and call our authorized service provider for rectification of problem.

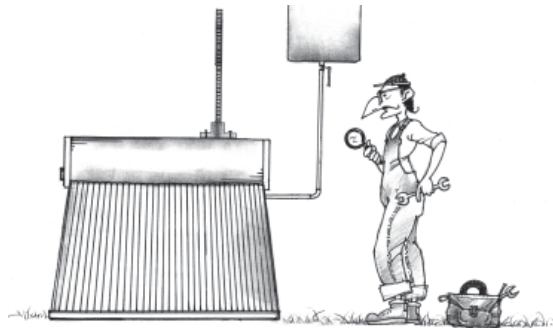
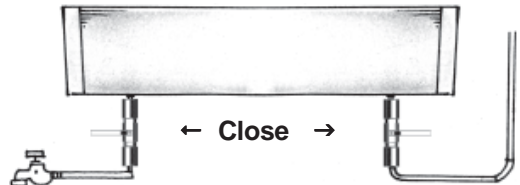

Working Principle of a Solar Water heater

A solar water heating system consists of a vacuum glass tube collector, an insulated storage tank and connecting stand parts (page 4). The evacuated glass tubes are filled with water and exposed to sun, thus heating up the water in the glass tubes.

As the specific gravity of cold water is heavier than hot water, the hot water in the glass tubes starts rising in the insulated water tank, and the cold water in the insulated water tank sinks into the glass tubes. As this cycle is repeated, water in the solar water heater gets heated. This process is known as thermosiphon and is based on natural convection (Fig.3)

The storage tank is insulated so the water stays hot and can be used later in the day or even the following day.

2 Inside View of Tank

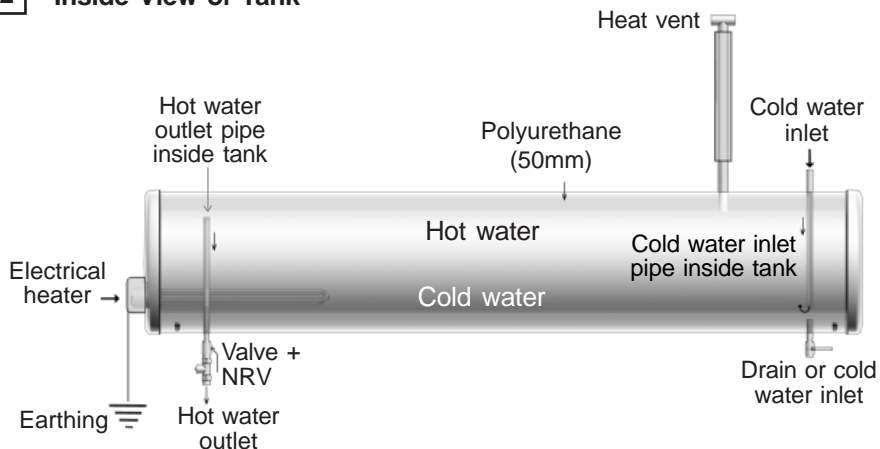

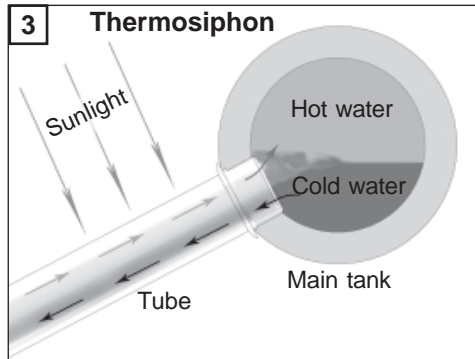

Performance

The output of a solar water heater system will depend on the amount of solar radiation available. On a good sunny day with 6 to 7 hours of sunlight, the glass tubes will collect enough solar energy to heat water up to 60°C. On a good sunny day the water temperature can rise very high and you may spot steam coming from the vent (this is perfectly normal).

Rainy days: These tubes perform very well in overcast conditions and in low temperatures. With evacuated glass tube technology, the reliability of the system increases, since the temperature inside the glass tube is independent of the surrounding temperature.

However, there is a provision for electrical back-up, which can be used on overcast days and on days when there is a need for additional hot water. (See Accessories, pg.23)

Installation Tips

It is essential that a certified/trained plumber and electrical technician carry out this installation.

1. The location of the solar water heater should be south facing on an even surface with plenty of sunlight and free of shadows between at least 9 am and 4 pm.(Fig.4).

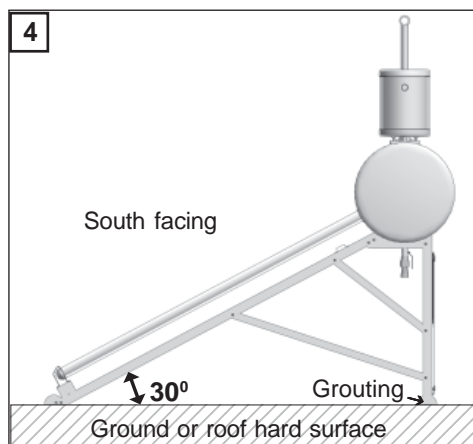

2. The solar water heater is designed to be used with a maximum head of 4 meters of water. It should be connected to an overhead water tank, the bottom of which should be at least one meter above the top of the solar system and not more than 3 meters high (Fig.5).

3. Wherever wind speed is high, the solar water heater should be grouted properly to the roof of the building. (Fig.4) A lightning-conductor can be fitted if required.

4. Connect the cold water inlet port preferably by a dedicated pipeline from the overhead water tank.

5. Connect a valve to the hot water outlet port (Fig.5,6) to shut off the flow of hot water for maintenance, or in case of leakage or any other emergency.

6. The distance between usage points and the solar water heater should be minimised as much as possible; the maximum recommended distance with insulated hot water pipe line without substantial heat loss is 12 meters.

5 Pipeline Installation with Vent grouting

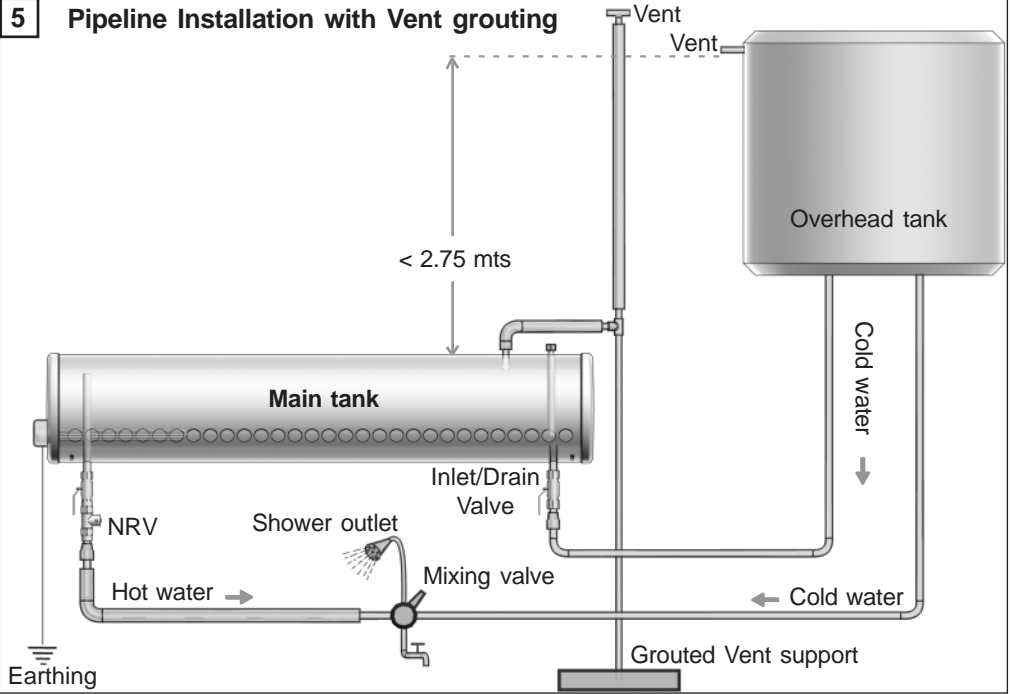

6 Pipeline Installation with Pressure Pump

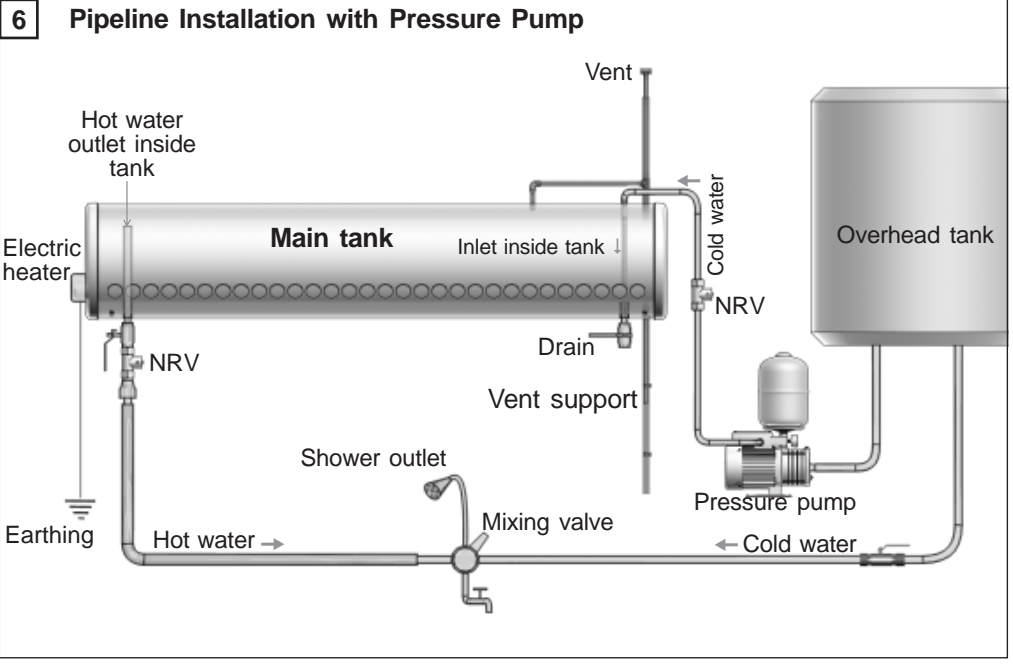

7. The recommended number of usage points are:

100 & 125 Litres = 1 - 2 usage points
150 & 200 Litres = 3 - 4 usage points
250 & 300 Litres = 5 - 6 usage points

8. In case your solar water heater runs out of water due to non usage it is necessary to ensure the first filling of cold water is done in the early morning hours when the temperature within the tubes is low to avoid damage to the glass tubes.

9. After the installation, let the solar water heater heat the water for a minimum of 6 hours of good sunlight before using the hot water.

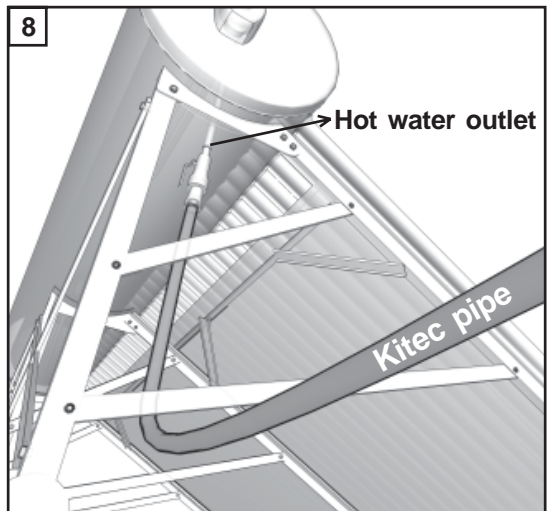
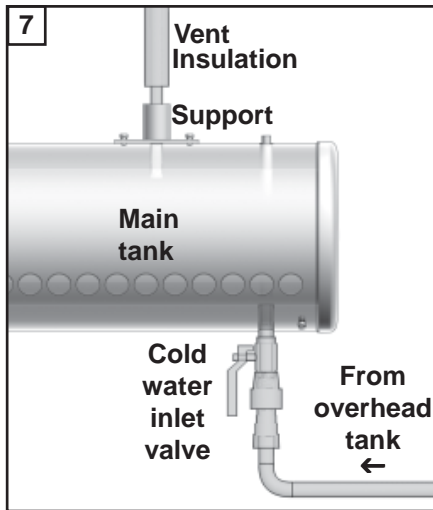

Optimal Usage Tips / Maintenance

There are some recommendations and tips which if followed can go a long way to improve the overall efficiency of the solar water heater.

1. **Plan the consumption** of hot water in quick intervals at one time (either in the morning or evening) to **minimize** heat loss in the pipeline.
2. **Run the hot water slowly**, this will avoid the mixing of hot and cold water in the solar water heater main tank.
3. **Do not withdraw more than the rated capacity** of the system on a single day.
4. **Use electrical backup occasionally** when more hot water is required.
5. **Set the thermostat of the electrical backup at 40 degree centigrade**. This is usually sufficient for a hot water shower. A higher setting will increase your electricity bills.

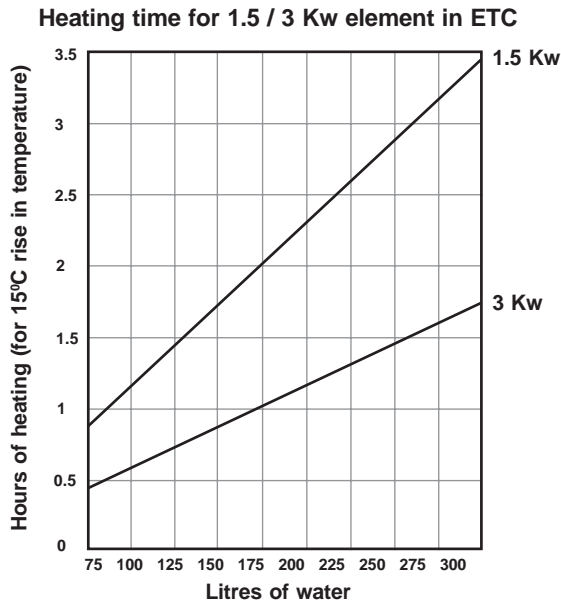

6. **Paint the MS support stand once in four – five years**. Though the supporting structure and other MS parts are powder coated for long rust-free life, inspect occasionally and paint them if needed.

7. **Regularly inspect the solar water heater tank** to make sure it's not damaged and that no rainwater runs into the tank insulation. Also check for any rusting in the plumbing lines. Do necessary repairs using the authorized service provider.

8. **To drain the water from solar water heater** (for cleaning or repair) Disconnect the cold water inlet pipe line and open the cold water inlet valve (Fig.4).

9. **If the water in your area is hard** it is recommended to clean the solar water heater main tank and glass tubes with fresh water once a year to flush out the settled scales. In places where the hardness of water is very high, it is advised to clean the solar water heater more frequently.

10. **Do not to carry out any repairs** or replacement of parts of the solar water heater on your own. Consult your **authorized service provider for help**.

11. **Ask your authorized service provider for an Annual Maintenance Contract** once the warranty period is over. Check with him for an updated version of the owners guide.

After Care (Do's & Don'ts)

1. This is a non-pressurized solar water heater and it should not be connected directly to a pressure pump or more than four metres of water pressure. Check with Authorized Service provider for more information.

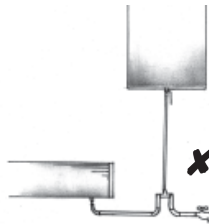
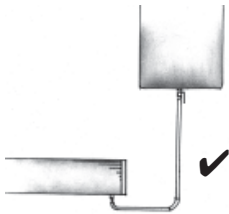
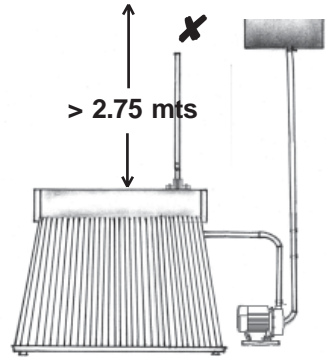
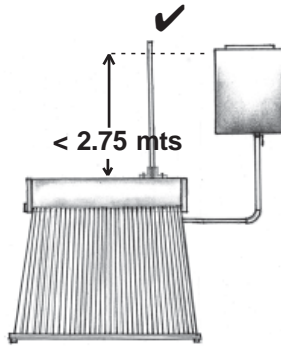

2. Do not connect any other equipment to the cold water inlet line of the solar water heater.

3. Do not use a pipe-wrench. If the system has to be disassembled and reassembled care should be taken not to use a pipe-wrench to connect the cold water, hot water and vent pipes to the solar water heater. If you do, it may cause severe damage to the tank and result in water leakage.

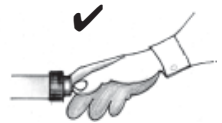
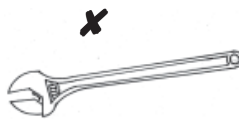

After use

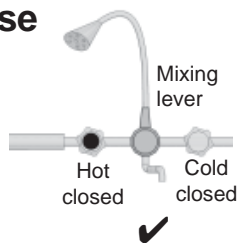
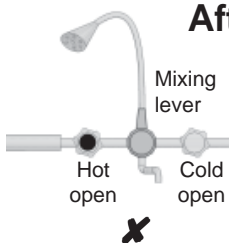

4. If mixing valves are used it is strongly advised to close the hot water and cold water tap after use and to keep the mixing lever in the middle position.

5. The **water temperature can be very high** in the summer months and steam can be observed coming out of the vent pipe. If the solar water heater is not in use in the summer or for a long period of time, it is advisable to cover the glass tubes with a canvas cloth or a mat.

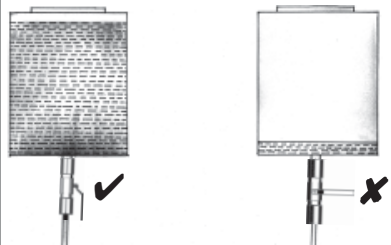
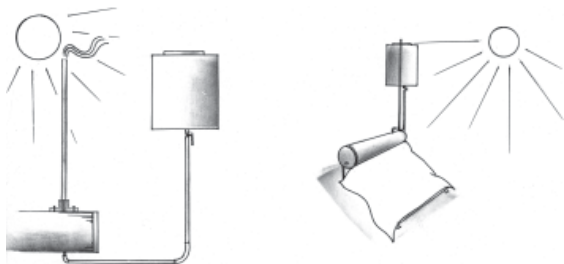

6. **Ensure that there is always a cold water supply to the solar water heater:** Leave the valve on the cold water inlet open and ensure that the overhead water tank is filled with water.

7. If the solar water heater tank has become empty due to non-supply of cold water for long periods, it should be refilled only during early morning hours when the temperature within the tubes is at a minimum.



8. **Clean the glass tubes regularly:**

If dust and dirt are allowed to settle on the glass cover it will block the sun's rays and reduce the efficiency of the system. It is advisable to clean the glass tubes every two weeks with fresh water or soft cloth. **Do not use coarse materials** while cleaning the glass tubes.

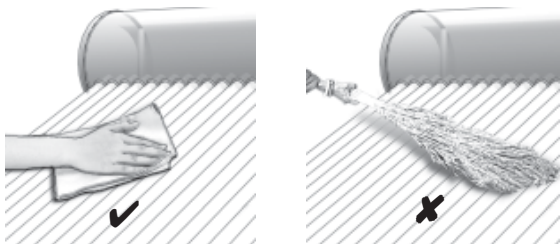

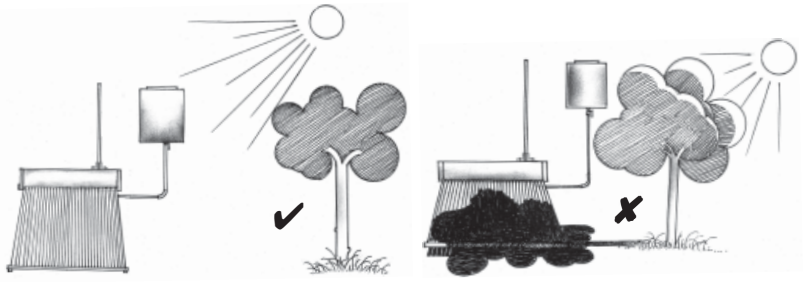

9. **Prevent any shade falling on the glass tubes:** Regularly trim back the branches of trees in the vicinity of the glass tubes to allow as much as possible sunlight to fall on them.

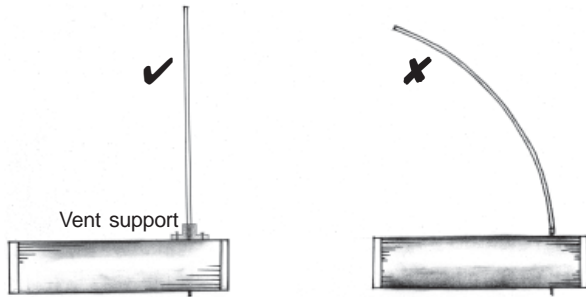

10. **Regularly check the vent to ensure it is not bent and is firmly supported using a vent support. Get it fixed immediately** if any damage is noticed in the vent pipe or the support structure. **Do not close, bend or block the vent pipe.** It is essential that the vent pipe be open to the atmosphere and that it is higher than the cold water storage tank, otherwise it may badly damage the system.

Trouble shooting

If after using this trouble-shooting guide, you still cannot solve the problem, please contact our **Authorized Service provider**.

Problem	Cause	Remedy
Water is not coming from the tap.	<p>a) Cold water inlet pipe from overhead tank or hot water outlet pipe from the solar water heater is choked by sediment or scales.</p> <p>b) No cold water supply to solar water heater from overhead tank.</p> <p>c) Cold water inlet valve is shut.</p> <p>d) Float valve in the make up tank has jammed or choked.</p> <p>e) Non-return valve stuck.</p> <p>f) Air is trapped in the cold or hot water pipe line.</p>	<p>a) Clean the pipes & descale sediment.</p> <p>b) Fill the overhead cold water tank.</p> <p>c) Open the valve.</p> <p>d) Clean the float-valve or replace it.</p> <p>e) Remove & clean NRV spring.</p> <p>f) Open the hot water outlet pipe near the valve and remove the air or drain the water out of the tank and fill it again.</p>
Not getting hot water.	<p>a) The solar water heater is not receiving enough sun light.</p> <p>b) Excess water consumption (Undersized).</p> <p>c) Incorrect connection of cold water and hot water pipes to solar water heater storage tank.</p> <p>d) Cloudy day, not enough sun light.</p> <p>e) Cold water pressure due to mixing valve preventing the hot water coming through.</p>	<p>a) Relocate in unshaded area.</p> <p>b) Plan your water usage as per installed capacity. In case of high consumption use the electric back-up.</p> <p>c) Shorten the hot water plumbing line or increase the capacity of the system.</p> <p>d) Use the electrical back-up.</p> <p>e) Run hot water slowly at first and then gradually open up the cold water tap for optimal mixing of hot and cold water at the point of use.</p>

Problem	Cause	Remedy
Hot water flow irregular.	a) Air vents of overhead tank and solar water heater is not provided or blocked. b) Air lock. c) Cold water inlet pipe inside tank choked by sediment or scales.	a) Provide suitable air vent for both the tanks, clean the vent pipe and put it back properly. b) Remove hot water outlet pipe from valve to clear air or drain and refill water from the solar water heater. c) Clean the pipe with long wirebrush after removing makeup tank.
Large drop in overnight temperature	a) Ineffective insulation. b) The insulation is wet. c) Excess heat loss in hot water pipeline	a) Check the insulation around the storage tank. b) Ensure that the insulation is dry. If it is wet due to rain leaking through the cladding, or due to a leak in the tank, then it will not keep the water in the system warm. c) Install as per installation guide lines.
The water is only luke-warm.	a) Cloudy day. b) Glass tubes not cleaned. c) The monkey protection mesh is dirty. d) Solar water heater not getting enough sun light. e) Reverse flow of cold water in to the solar water heater tank (In case of mixing valve). f) Hot water pipeline not insulated properly. g) Hard water scale deposits in the glass tube and tank. h) Excessive consumption of hot water the previous night.	a) Use electrical back-up, if provided. b) Remove dust which has accumulated on the glass tubes. c) Clean the monkey protection mesh regularly to avoid this problem. d) Relocate in unshaded area. e) Close cold & hot water tap of the mixing valve after use. f) Insulate the pipeline with suitable insulation. g) Clean the glass tubes and tank with fresh water. h) Plan your shower / bath according to the system's capacity, use electrical back-up heater if required.

Problem	Cause	Remedy
Water is boiling and steam is being released from vent.	<ul style="list-style-type: none"> a) System not in use for a long time. b) Failure of thermostat. 	<ul style="list-style-type: none"> a) If the system is not being used, cover the glass tubes with a shade or install a steam trap on the air vent. b) Change the thermostat.
Electrical backup not working.	<ul style="list-style-type: none"> a) Wrong wiring connections. b) Inappropriate thermostat temperature. c) Lightning strike. d) Short circuit. e) Electrical heater thermostat failure. 	<ul style="list-style-type: none"> a) Connect according to the wiring diagram. b) Set the thermostat for a comfortable bath between 35 - 45 degrees centigrade. c) Inspect / replace fuse, heater element and thermostat. d) Inspect / replace fuse, heater element and thermostat. e) Replace with a new one.
The solar water heater is leaking.	<ul style="list-style-type: none"> a) The solar water heater or plumbing line has a leak. 	<ul style="list-style-type: none"> a) Try to determine the source of the leakage. If it is not rainwater, fix the leak. If the problem persists, call the authorized service provider.
Water overflows from air vent or make up tank.	<ul style="list-style-type: none"> a) Reverse flow of cold water in to the solar water heater tank (In case of mixing valve). b) Inappropriate air vent length. c) Float Valve stuck in the make up tank. 	<ul style="list-style-type: none"> a) Close cold & hot water tap of the mixing valve. b) Increase the length of the air vent as per installation guide lines. c) Clean or replace the float valve in the make up tank

Technical Specifications

Model	Aurore-100	Aurore-125	Aurore-150	Aurore-200	Aurore-250	Aurore-300
Number of users	3 to 4	4 to 6	6 to 7	7 to 8	9 to 11	11 to 13
Storage tank volume	100 litres	125 litres	150 litres	200 litres	250 litres	300 litres
Usage points	2	2	3	3 - 4	5 - 6	5 - 6
Number of tubes	12	15	18	24	30	36
Tube diameter	47 mm					
Tube length	1800 mm					
Tube layers	3					
Tube coatings	Cu / SS / A1-N / A1					
Outer tube thickness	1.8 mm					
Inner tube thickness	1.6 mm					
Joints & seals	Non-welding technology used for all joints					
Outer tank <i>option</i>	AISI-304-2B grade painted steel -- 0.4 mm thickness					
Inner tank	AISI-304-2B grade - 0.6 mm thickness					
Outer tank diameter	475 mm					
Inner tank diameter	375 mm					
Tank insulation	50 mm PU(Polyurethane Foam)					
Support structure	Powder-coated mild steel with inbuilt vent support					
Max.system pressure	0.4 Bar					
Water temperature	> 94° C					
Electrical backup	1.5 Kw					
Thermostat	30° C to 70° C					
Tube life	> 15 years					
Tube warranty*	5 years					
Full system warranty*	1 year					

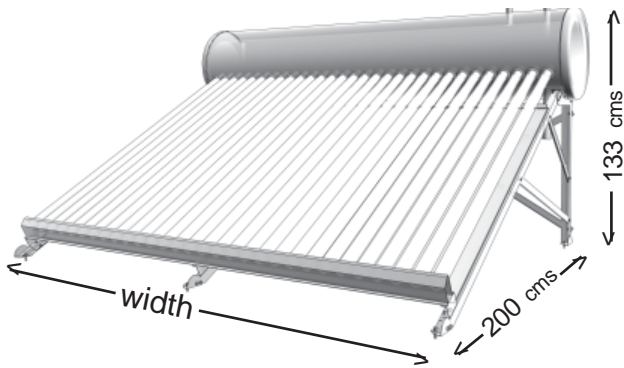

Model	Width (cms)
Aurore - 100	106
Aurore - 125	135
Aurore - 200	193
Aurore - 250	235
Aurore - 300	300

Accessories

Makeup Tank: The Domestic Solar water heater is designed to be used with a maximum pressure of 2.75 meters of water. If it is more than 2.75 meters of water column or if a pressure pump is being used then a small insulated steel tank called "Make up tank" should be installed to reduce the pressure.

Electrical heater: Domestic solar water heaters have a provision for installing a 1.5 or 3 KVA back-up electrical heater with a built-in thermostat. The heater can be used on days when there is no sun or if the hot water requirement increases suddenly.

Plumbing: 1/2 Kitec pipes for inlet, outlet, drain and vent. Insulation sleeve for vent. Non-return valve (NRV) at outlet.

WARRANTY CARD

Upon installation of the solar water heater, the dealer responsible for the sale will fill out the warranty card and the customer will complete a record of it and retain it for future servicing.

This limited warranty covers the glass tubes, hot water tank and tank support frame for tube-breakage, leakage or any other malfunction caused by defects in the materials and/or workmanship. It extends to the first buyer and to any subsequent owner(s) as long as the water heater has been installed by trained and qualified authorized technicians approved by the local dealer.

On glass tubes the limited warranty is for a period of 5 years from the date of purchase. This warranty excludes loss of vacuum in a tube or tubes due to breakage during transport, handling or after installation. A gradual reduction in vacuum levels over time is normal and accordingly is not a defect in terms of this warranty.

The limited warranty on the hot water tank and support frame is for a total period of 1 year from the date of purchase

This warranty also does not cover:

Cover leakage or breakage of tubes or other malfunctions caused by defective installation, misuse, operation and maintenance contrary to the written instructions in the user manual.

Odiferous, discoloured or rusty water coming from the system.

Damage to surrounding area or property caused by leakage or malfunction of the system.

Costs associated with the replacement and/or repair of the unit, including freight, shipping or delivery charges, removal, installation or re-installation charges; any material, and/or permits required for installation, re-installation or repair.

All legal disputes to be settled in Puducherry.

To facilitate warranty service, you should:

1. Follow all instructions enclosed with the product.
2. Retain all bills of sale or receipts for proof of installation, etc.
3. Contact your installer or dealer as soon as any problem or defect is noticed.
4. When necessary, allow our chosen representative, to inspect the unit.

Product Model No.....

Product Serial No.....

Name of Purchaser:

.....

Address:

.....

.....

Phone No:.....

Email

Date of Purchase

Dealers Name:

.....

Dealer's Stamp / Date:

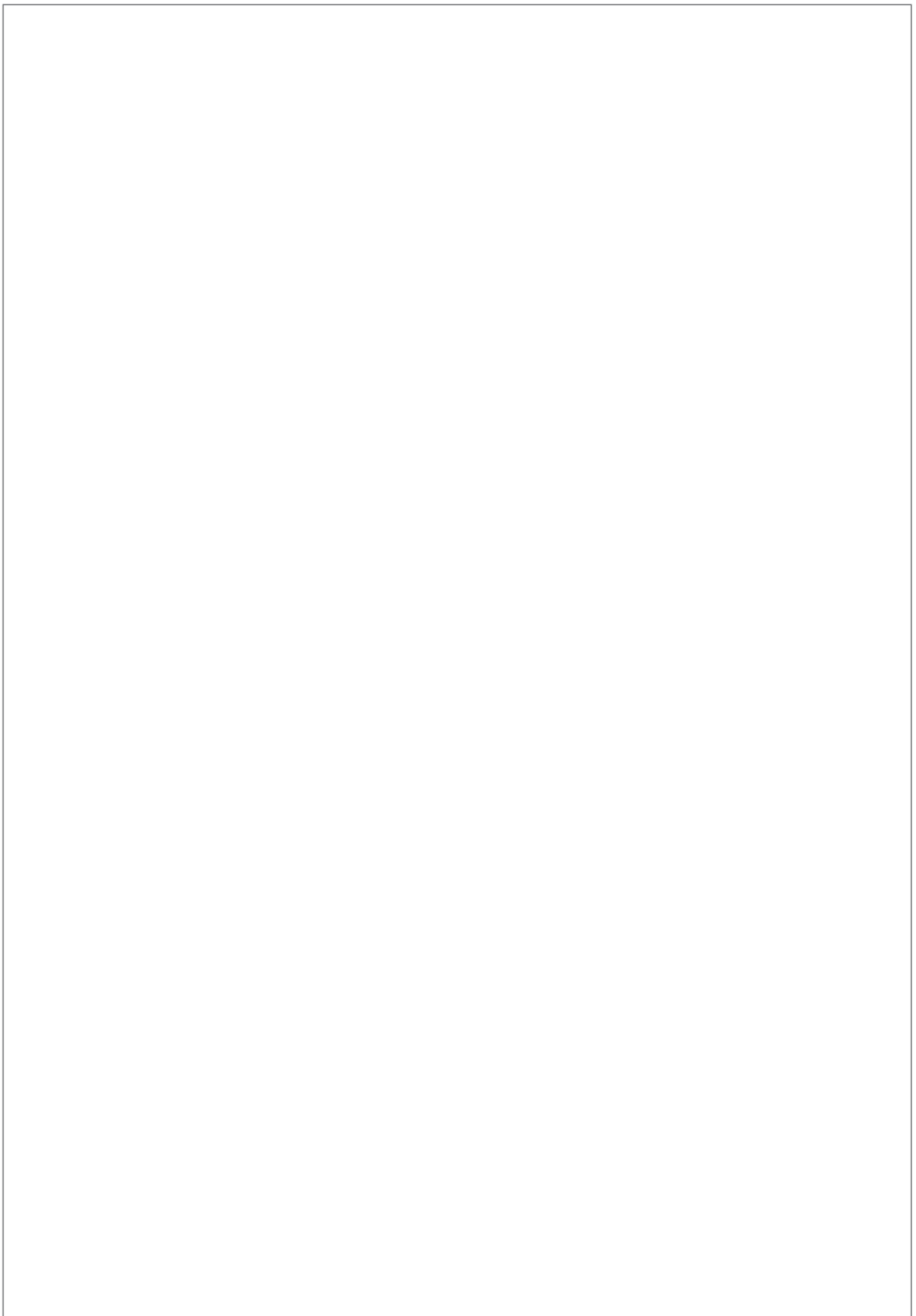



Solar Water heaters

Represented by :

A U R O R E
Auroville Renewable Energy

CSR Office, Auroshilpam, Auroville 605101, Tamil Nadu.
Phone: 0413-2622749 / 168 / 277 Fax: 0413-2622057
email: aurore@auroville.org.in
<http://www.auroville.com/aurore>